



# 24-C Ford Ranger Raptor Mud Flap Set, Front Mounting Diagram & Instructions Kit# GCR416F

## IMPORTANT:

Manufacturer is not responsible for negligent use of vehicle with mud flaps installed, including over-tightening of screws and bolts causing damage to vehicle or mud flaps.

## TOOLS REQUIRED-

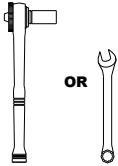

OR

7mm Open Wrench or  
Socket Wrench

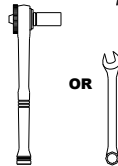

OR

1/4" Open Wrench or  
Socket Wrench

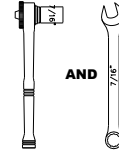

AND

7/16" Open Wrench and  
Socket Wrench



Push Pin  
Removal Tool

## FLAPS & BRACKETS

(1) Flap Assembly,  
Front, DS

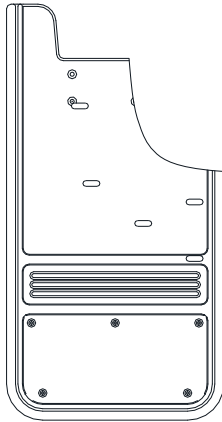

(1) Flap Assembly  
Front, PS

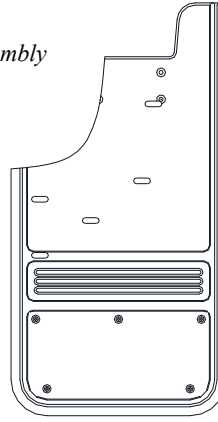

## PARTS BAG # 771269

a) (4) Cap Screw, SS Blk Ox.  
1/4-20UNC x 1"  
Part #014073



b) (4) Cap Screw, SS Blk Ox.  
1/4-20UNC x 1.5"  
Part #014074



c) (4) Sheet Mtl Screw  
#8-15 x 1" SS Blk. Ox.  
Part #016057



d) (8) Washer, Flat  
0.281" x 1" SS Blk Ox.  
Part #018069

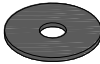

e) (4) Washer, Flat  
0.203" x 1" SS Blk Ox.  
Part #018070



f) (8) Spring Nut, SS  
1/4"-20UNC, 0.54" Reach  
Part #028010

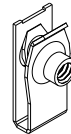

g) (6) Washer, Black Nylon  
0.281" x 1" x 0.062"  
Part #054085



h) (6) J-Clamp  
1.5" x 4" Anodized  
Part #769802

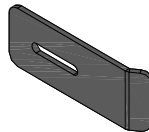

i) (2) Impart Bar Bracket  
Universal  
Part #770892

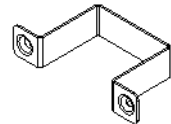

## INSTALLATION *(For ease of installation it is suggested that the wheel be removed)*

Before you install your Mud Flap Set, see the diagram and parts list for all necessary parts.

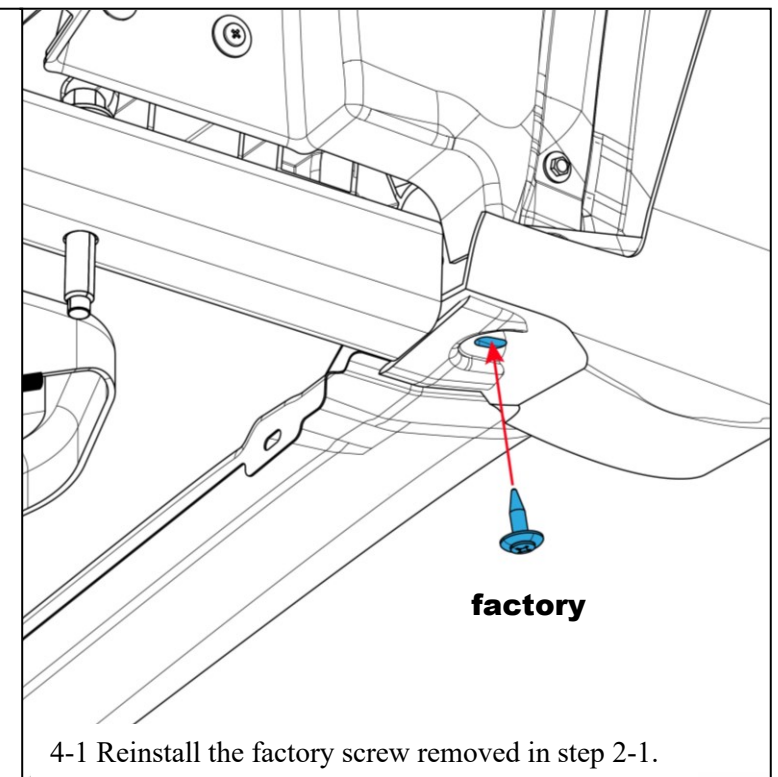
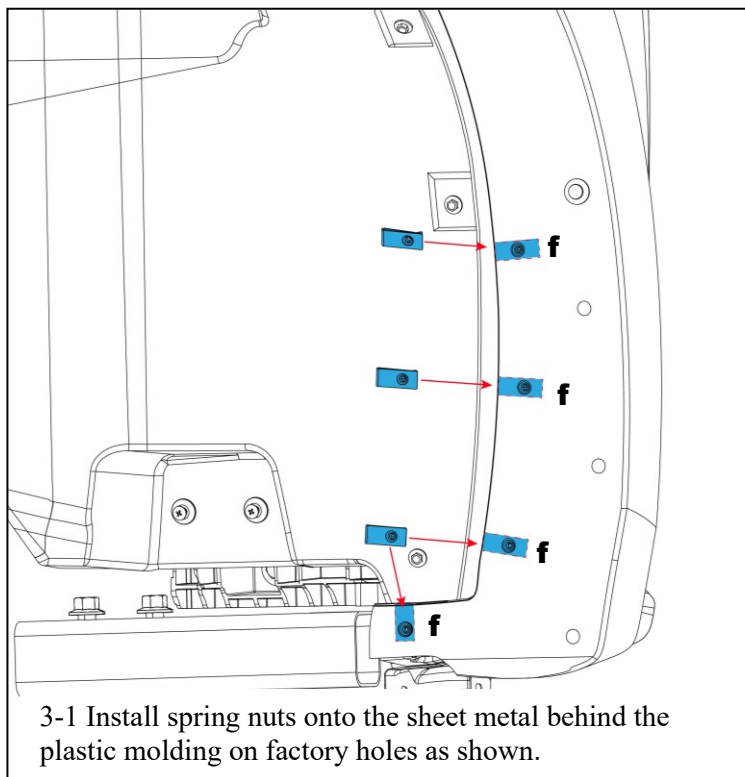
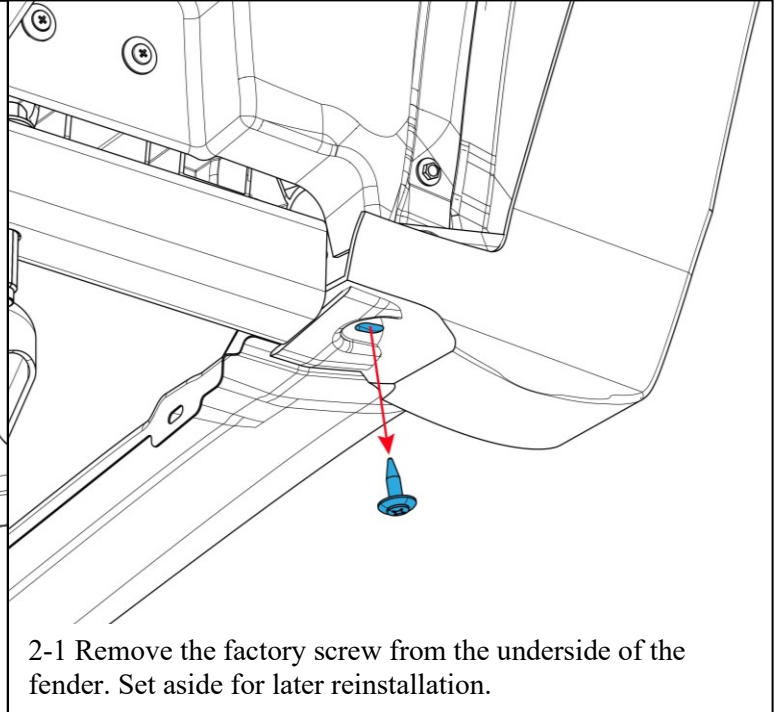
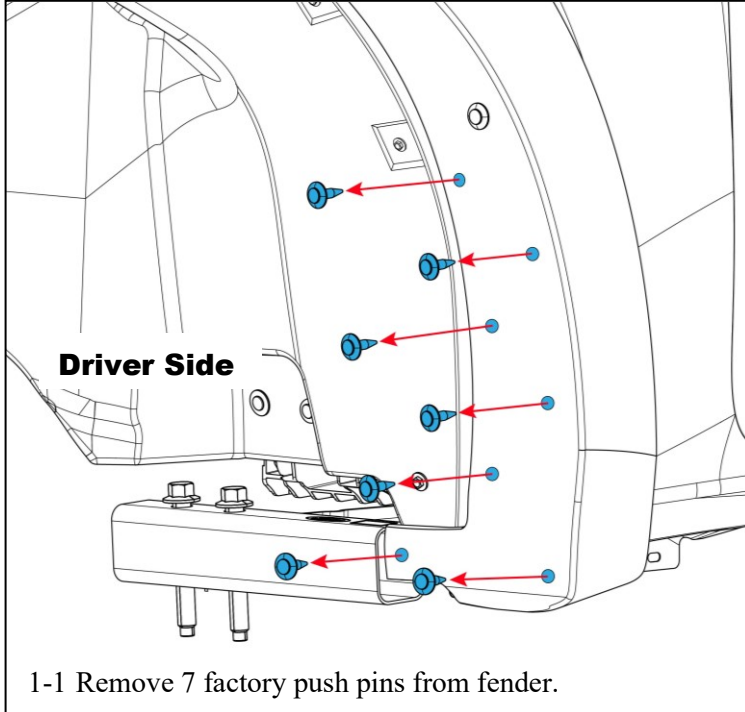

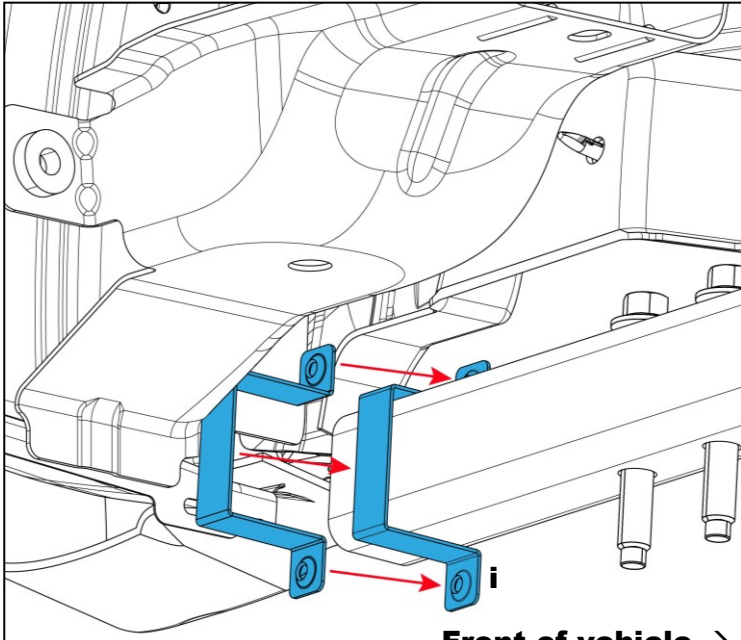

**Front of vehicle** →

5-1 Install bracket on impact bar from behind so the flanges face the tire.

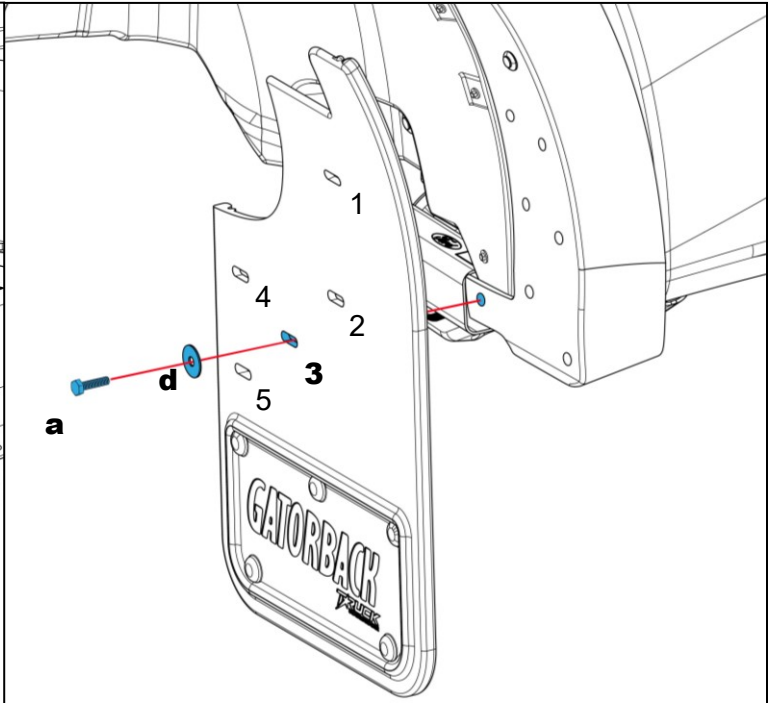

6-1 Loosely secure mud flap hole #3 to spring nut as shown

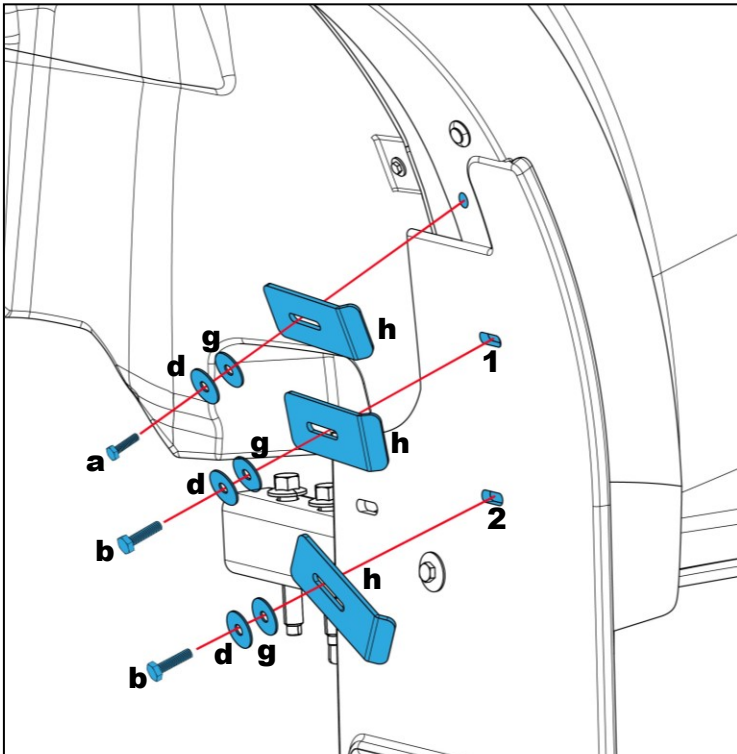

7-1 Loosely secure mud flap holes #1 & #2, as well as top portion of mud flap, to the spring nuts on the factory holes as shown.

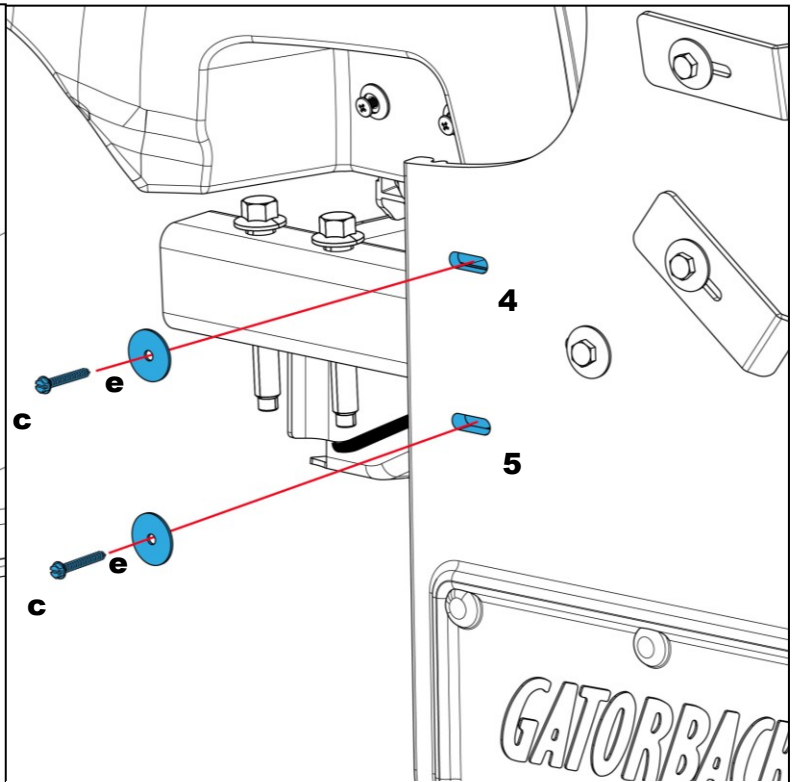

8-1 Loosely secure mud flap holes #4 & #5 to bracket as shown.

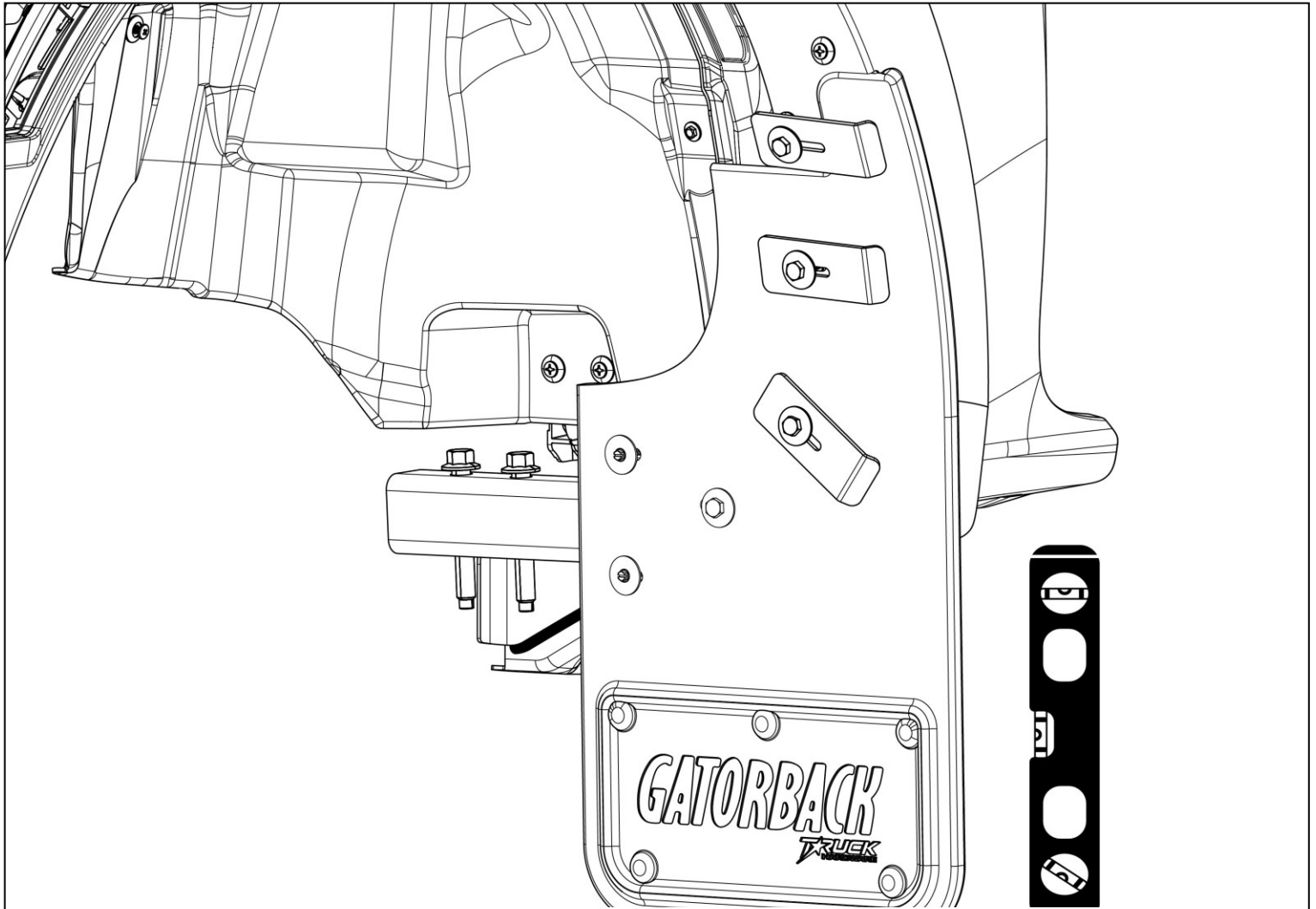

9-1 Using a square or other leveling tool, ensure mud flap is level and tighten all fasteners. We strongly suggest tightening All fasteners with hand tools, **not** power tools.

Note: Pay close attention to the angle of the J-clamps. These are to apply pressure to the rubber so it sits tight against the wheel well.

Repeat procedure on the passenger side.

Please check out our YouTube channel to see an install video for this application  YouTube



1520 - 33 St N • Lethbridge, AB T1H 5H3 • Canada  
Toll free: 1-800-661-8208 • Email: info@truckhardware.ca • www.truckhardware.ca





**IMPORTANT:**

**Manufacturer is not responsible for negligent use of vehicle with mud flaps installed, including over-tightening of screws and bolts causing damage to vehicle or mud flaps.**

**TOOLS REQUIRED-**

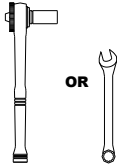

OR

7mm Open Wrench or  
Socket Wrench

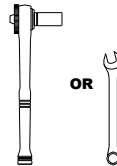

OR

1/4" Open Wrench or  
Socket Wrench

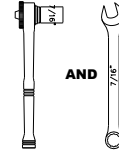

AND

7/16" Open Wrench and  
Socket Wrench



Push Pin  
Removal Tool

**FLAPS & BRACKETS**

(1) Flap Assembly,  
Rear, DS

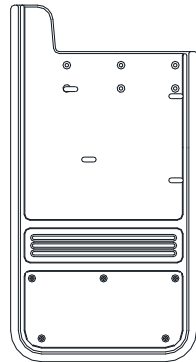

(1) Flap Assembly  
Rear, PS

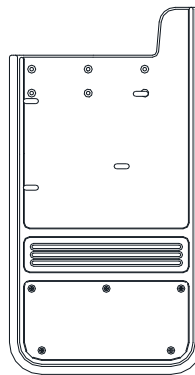

**PARTS BAG # 771270**

**a)** (6) Cap Screw, SS Blk Ox.  
1/4-20UNC x 1"  
Part #014073

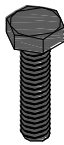

**b)** (4) Cap Screw, SS Blk Ox.  
1/4-20UNC x 1.5"  
Part #014074



**c)** (20) Washer, Flat  
0.281" x 1" SS Blk Ox.  
Part #018069

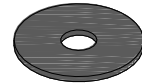

**d)** (10) Washer, Lock  
1/4" Helicoil, Stainless  
Part #024000



**e)** (10) Hex Nut  
1/4"-20, Stainless  
Part #025000



**f)** (6) Washer, Black Nylon  
0.281" x 1" x 0.062"  
Part #054085

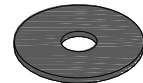

**g)** (6) J-Clamp  
1.5" x 4" Anodized  
Part #769802

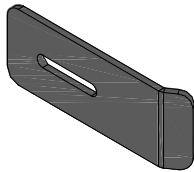

# INSTALLATION *(For ease of installation it is suggested that the wheel be removed)*

Before you install your Mud Flap Set, see the diagram and parts list for all necessary parts.

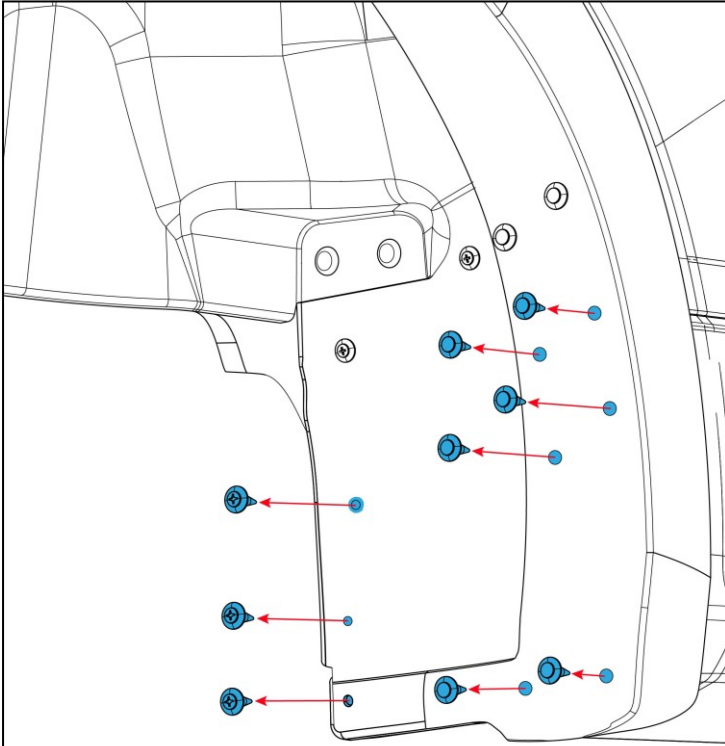

1-1 Remove 6 factory push pins from the fender and 3 factory screws from the liner as shown.

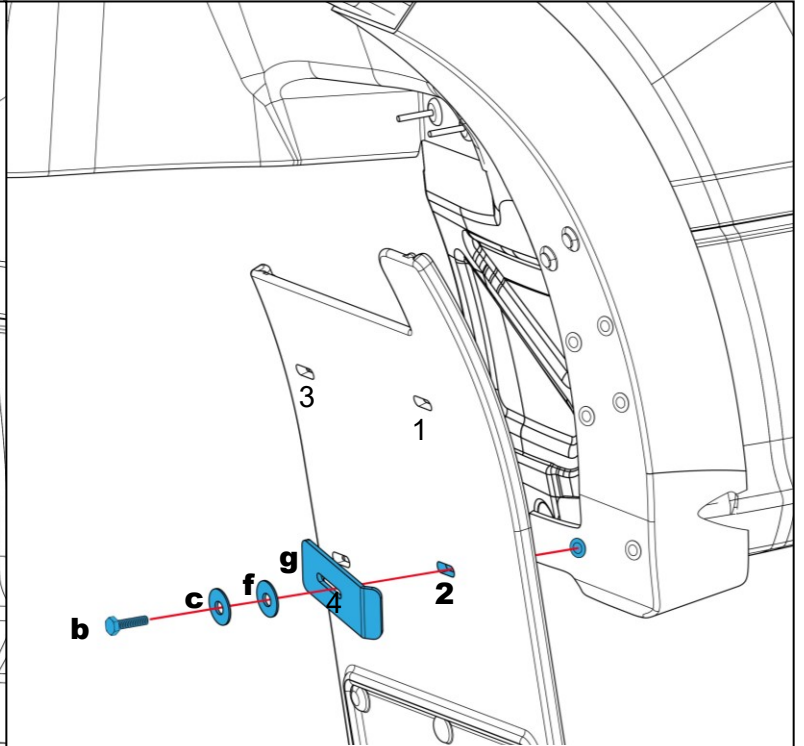

2-1 Loosely install mud flap hole #2 through factory hole as shown.

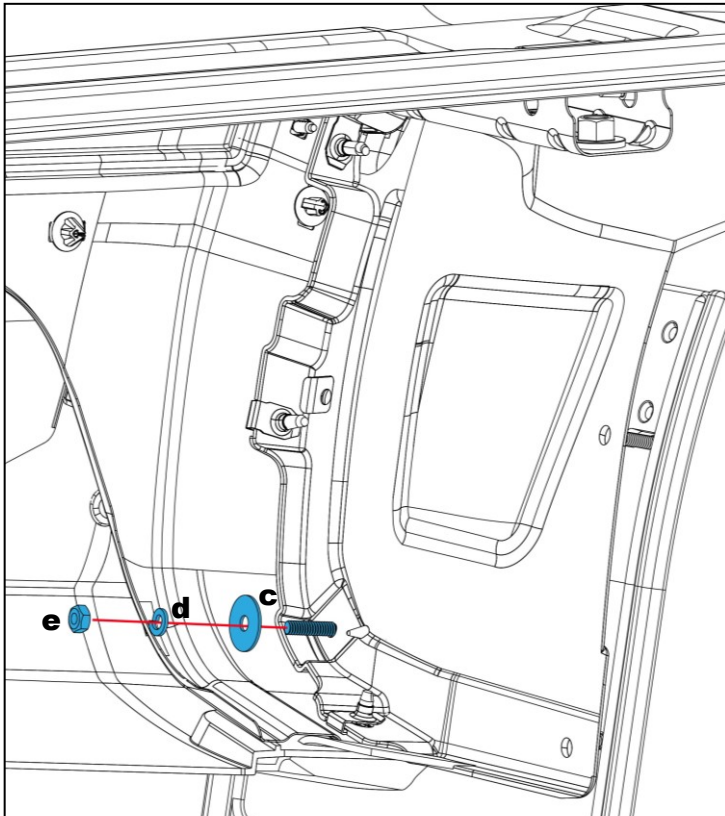

2-2 Loosely secure hardware installed in 2-1 from the back as shown.

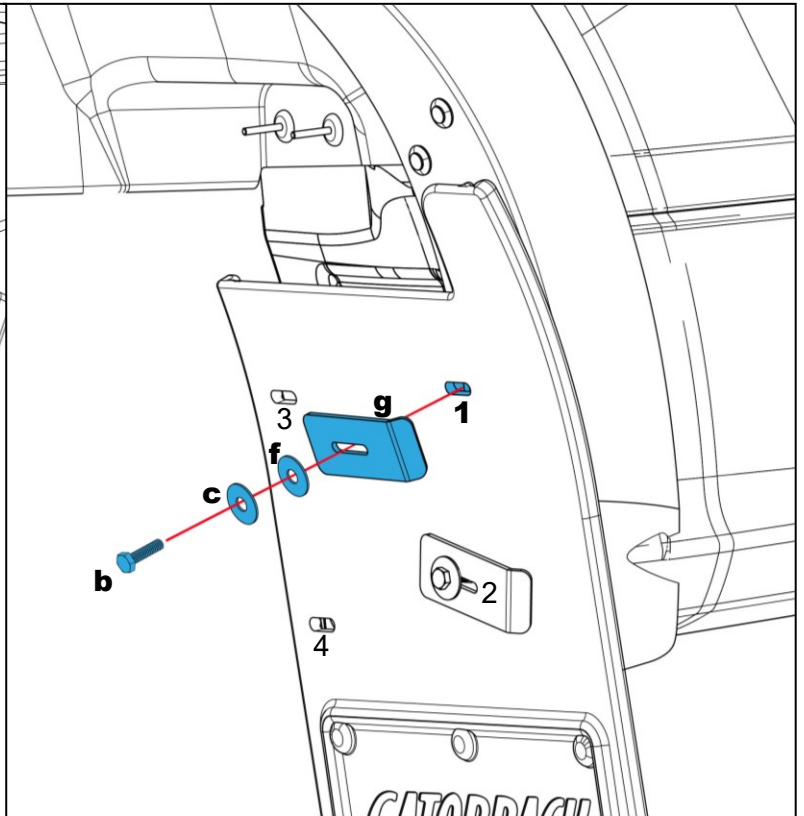

3-1 Loosely install mud flap hole #1 through factory hole as shown.

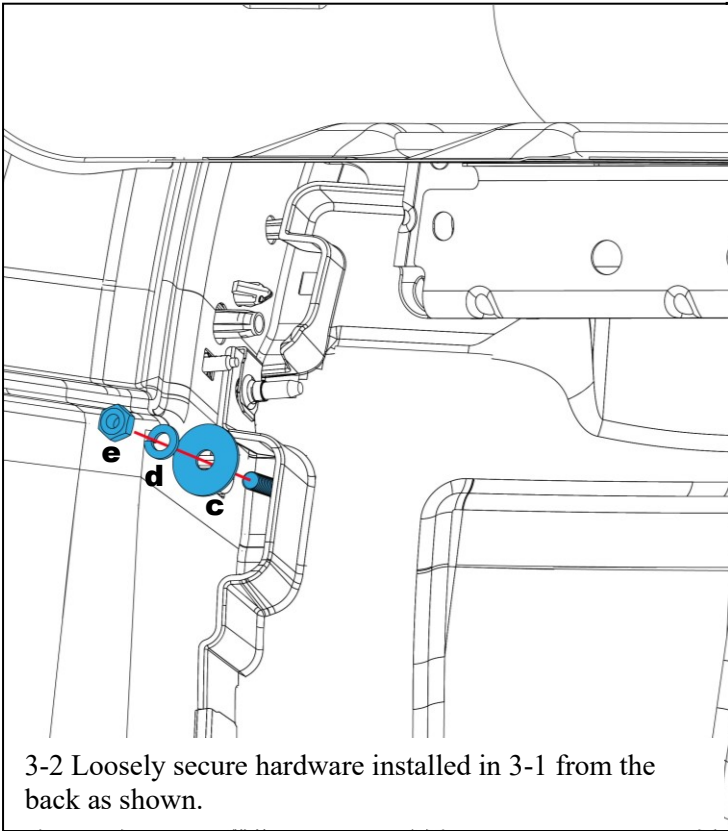

3-2 Loosely secure hardware installed in 3-1 from the back as shown.

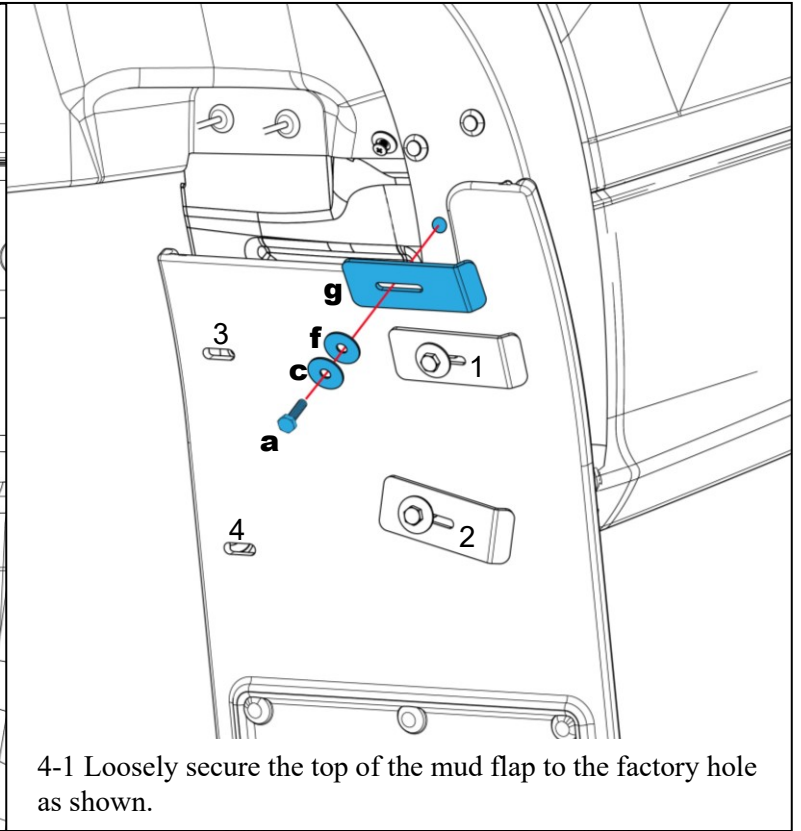

4-1 Loosely secure the top of the mud flap to the factory hole as shown.

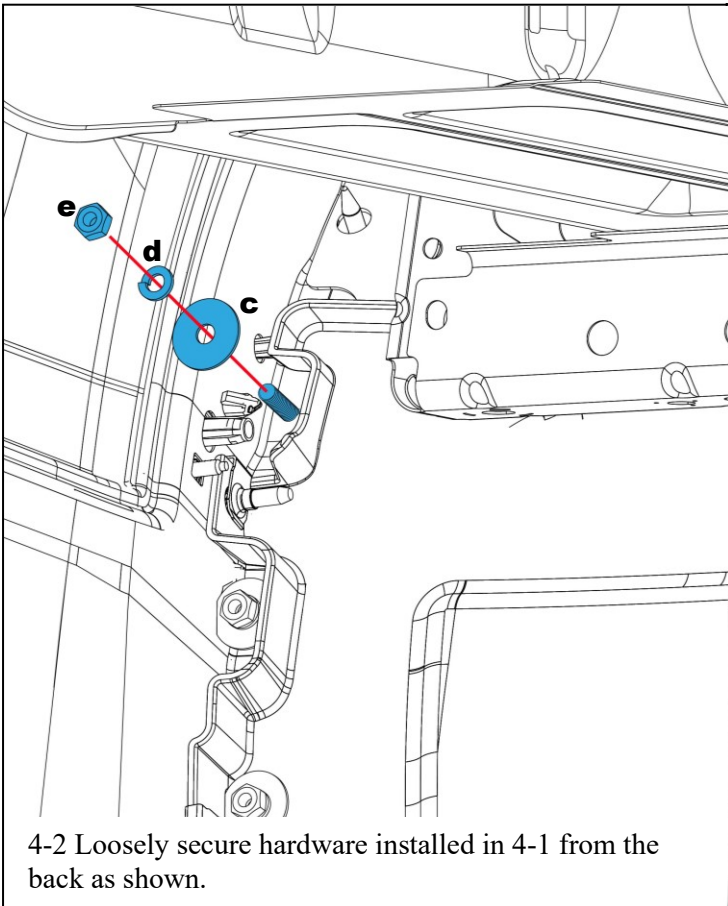

4-2 Loosely secure hardware installed in 4-1 from the back as shown.

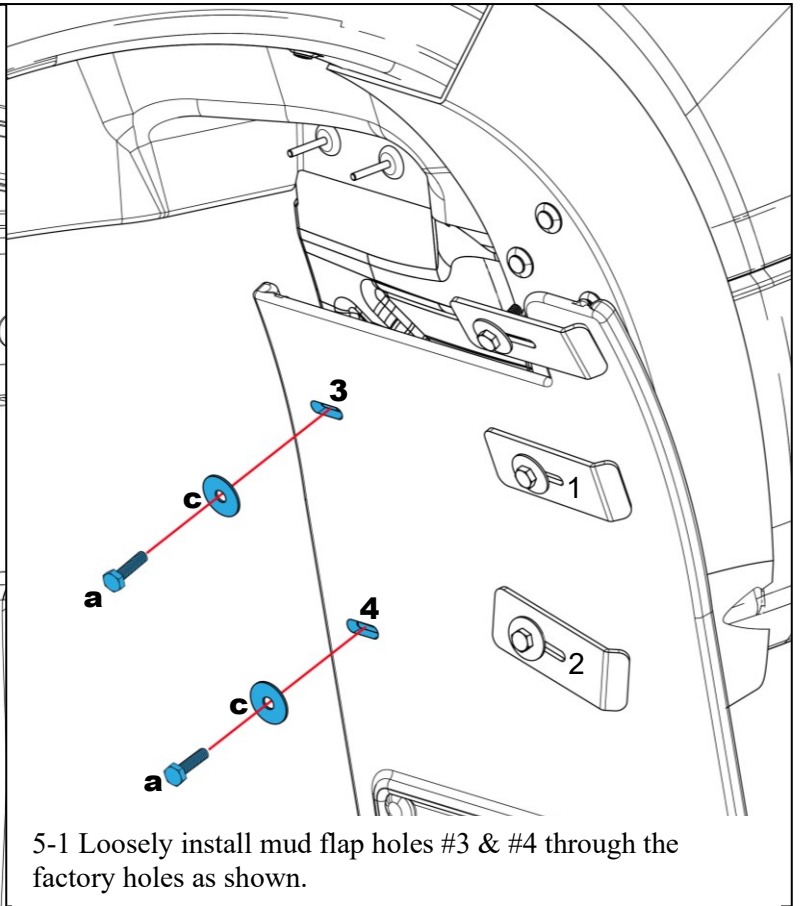

5-1 Loosely install mud flap holes #3 & #4 through the factory holes as shown.

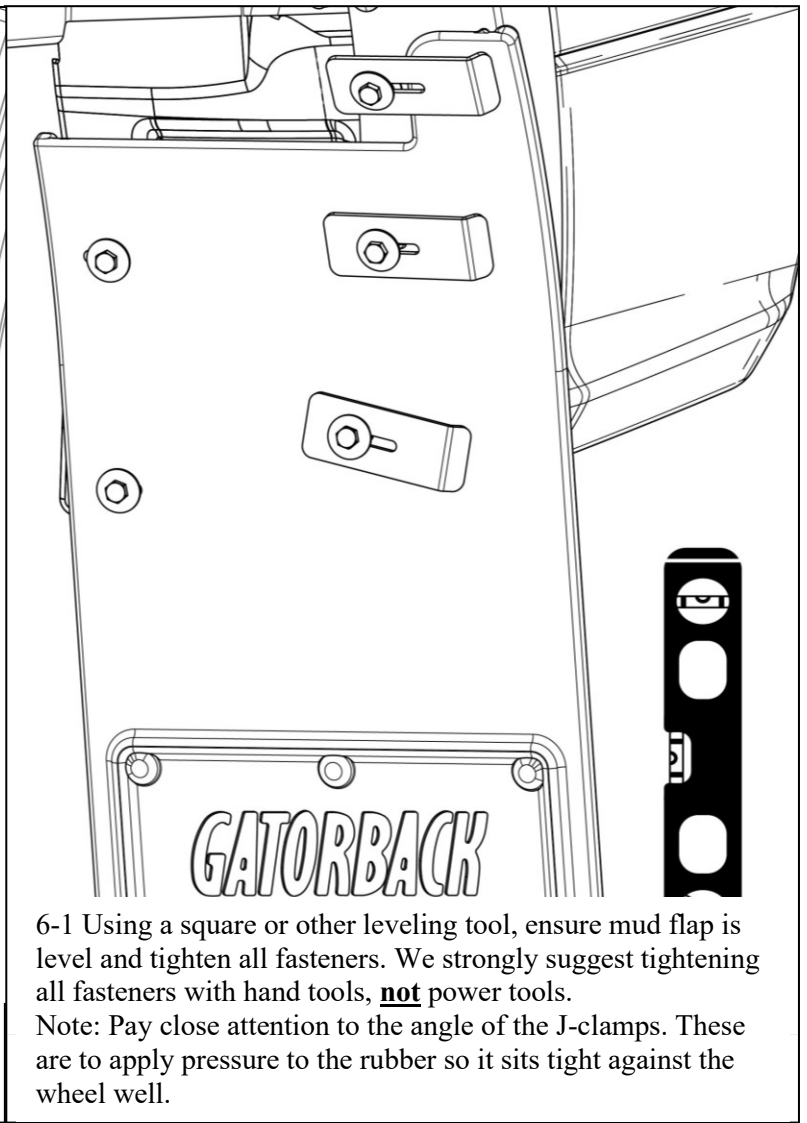
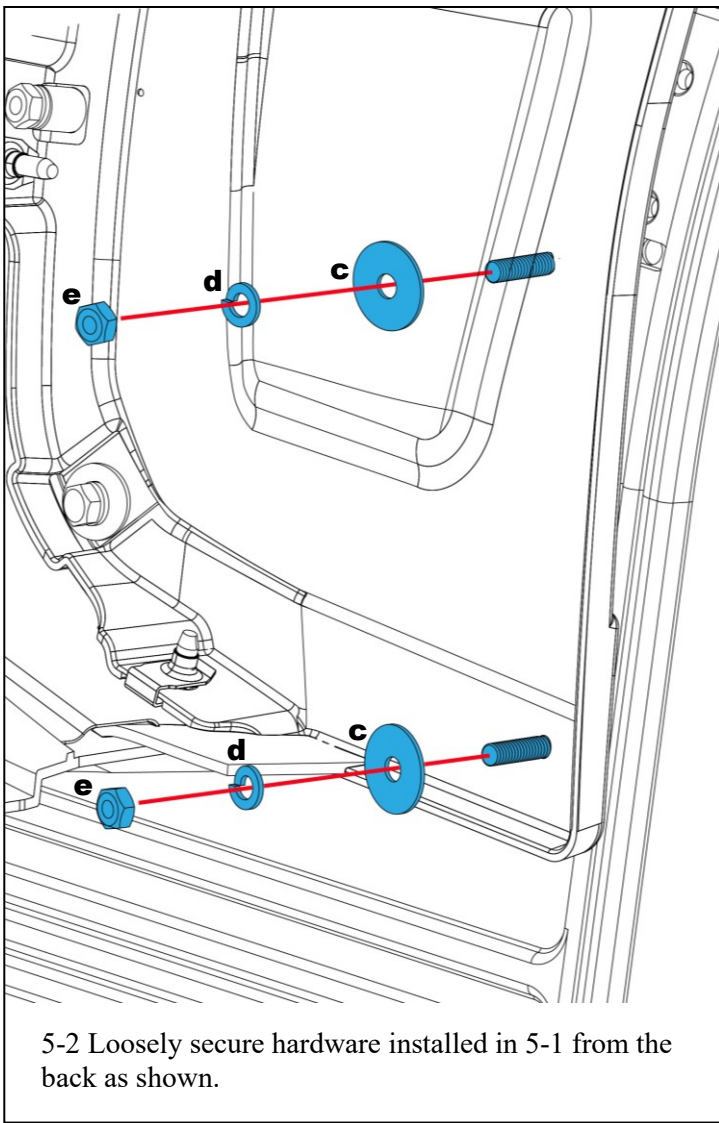

Repeat procedure on the passenger side.

Please check out our YouTube channel to see an install video for this application



1520 - 33 St N • Lethbridge, AB T1H 5H3 • Canada  
 Toll free: 1-800-661-8208 • Email: info@truckhardware.ca • www.truckhardware.ca

